

EE 4350
Spring 2025

Lecture 1

Course Outline
Amplifier Design Issues

Instructor:

Randy Geiger

2133 Coover

rlgeiger@iastate.edu

www.randygeiger.org

294-7745

Teaching Assistants:

Matthew Crabb

mjcrabb@iastate.edu

Course Information:

Analog VLSI Circuit Design

Lecture: MWF 9:55-10:45 Rm 1016 Coover

Labs: Wed 11:00-2:00
Thur 11:00-2:00

Course Web Site: <http://class.ece.iastate.edu/ee435/>

Course Wiki: <http://wikis.ece.iastate.edu/vlsi>

Zoom Link:

<https://iastate.zoom.us/j/93612086620?pwd=KIXt08Fbzebel8IJux5VHsmzvLExE0.1>

Passcode: 339848

Course Description:

Basic analog integrated circuit and system design including design space exploration, performance enhancement strategies, operational amplifiers, references, integrated filters, and data converters.

Instructor Access:

- Office Hours
 - MWF 11:00 – 11:50
 - Or by appointment
- Email
 - rlgeiger@iastate.edu
 - Include **EE 4350** in subject

Course Information:

Required Text:

Analog Integrated Circuit Design (2nd edition)
by T. Carusone, D. Johns and K. Martin, Wiley, 2011

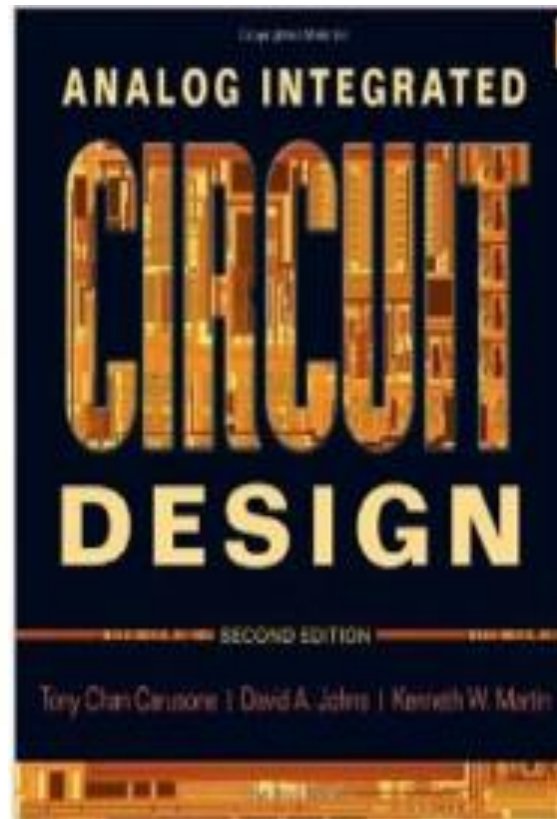

Course Information:

Reference Texts:

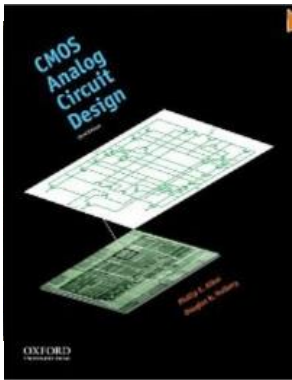

CMOS Analog Circuit Design (3rd edition)
by Allen and Holberg, Oxford, 2011.

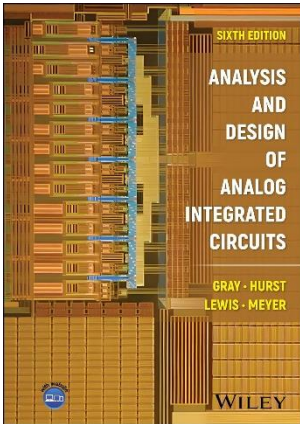

Analysis and Design of Analog Integrated Circuits-
6th Edition
Gray, Hurst, Lewis and Meyer, Wiley, 2024

Course Information:

Reference Texts:

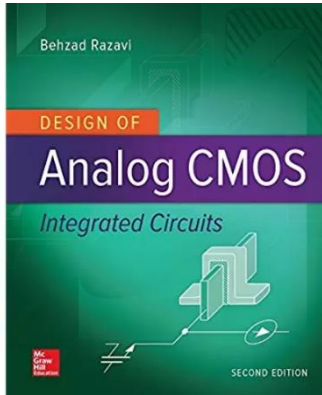

Design of Analog CMOS Integrated Circuits – second edition
by B. Razavi, McGraw Hill, 2017

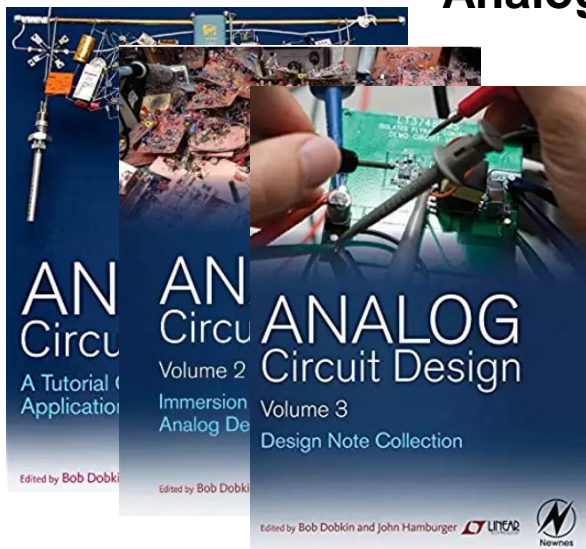

Analog Circuit Design – Vol 1 (2011), Vol 2 (2013) and Vol 3 (2014)
by B. Dobkin and Jim Williams, Newnes

Course Information:

Reference Materials:

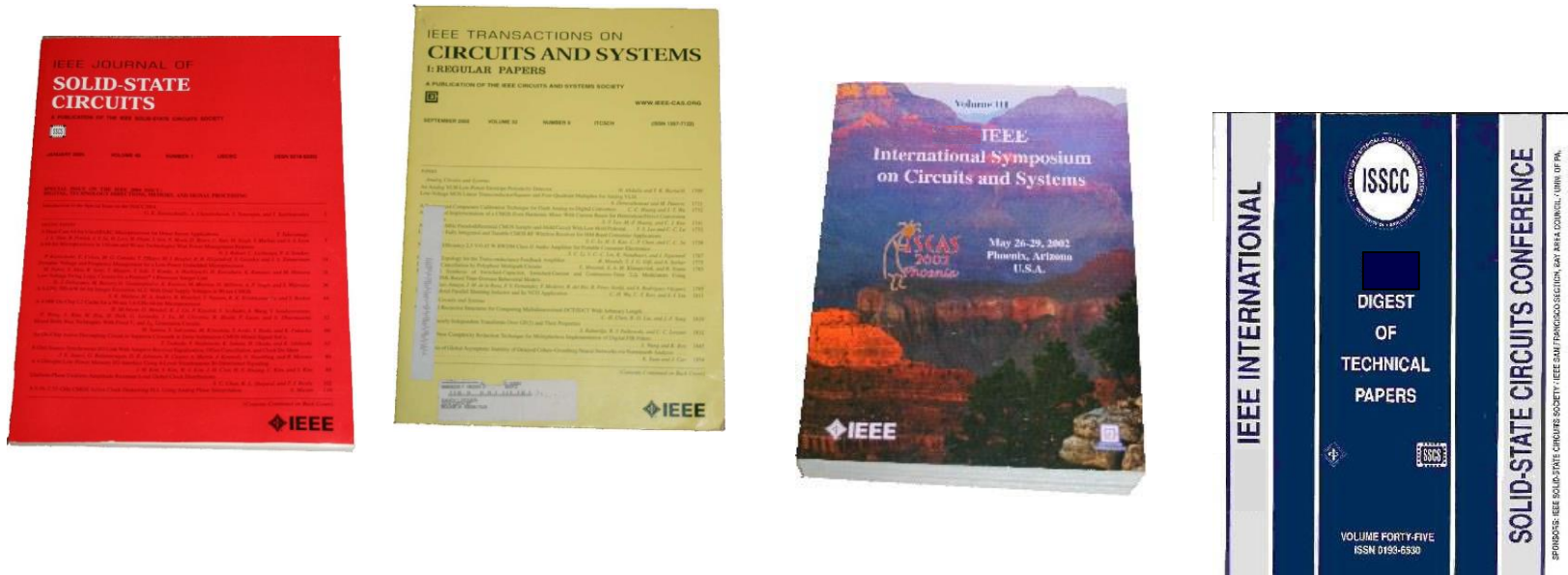

Welcome to the only official Website of the

For Search

UNITED STATES PATENT AND TRADEMARK OFFICE
An Agency Of The United States Department Of Commerce

[Text Only](#) | [Site Index](#) | [FAQ](#) | [Glossary](#) | [How To Guides](#) | [eBusiness](#) | [eBiz Alerts](#) | [News](#) | [Help](#) | [How To Search](#) | [Resources](#)

Course Information:

Grading: Points will be allocated for several different parts of the course. A letter grade will be assigned based upon the total points accumulated. The points allocated for different parts of the course are as listed below:

2 or 3 Exams	300 pts total
Homework	100 pts.total
Attendance	100 pts. total
Lab and Lab Reports	100 pts.total
Design Project	100 pts.

The exams (from during the semester or during finals week) will be equally weighted.

Course Information:

Design Project:

The final design project will be the design of an 8-bit to 10-bit digital to analog converter (DAC) or an analog to digital converter (ADC) – specifications to be determined. Additional details about the design project will be given after relevant material is covered in class. The design should be ready for fabrication and post-layout simulations are to be included as a part of the project.

There will also be an operational amplifier design project that will be graded as a part of the laboratory component of the course

Course Information:

E-MAIL: rlgeiger@iastate.edu

I encourage you to take advantage of the e-mail system on campus to communicate about any issues that arise in the course. I typically check my e-mail several times a day. Please try to include "EE 4350" in the subject field of any e-mail message that you send so that they stand out from what is often large volumes of routine e-mail messages.

Equal Access Policy:

Participation in all class functions and provisions for special circumstances including special needs will be in accord with ISU policy

Course Information:

Course Wiki <http://wikis.ece.iastate.edu/vlsi>

A Wiki has been set up for circuits and electronics courses in the department. Links to WEB pages for this course are on this Wiki. Students are encouraged to use the Wiki to share information that is relevant for this course and to access materials such as homework assignments, lecture notes, laboratory assignments, and other course support materials. In particular, there is a FAQ section where issues relating to the material in this course are addressed. Details about not only accessing a Wiki but using a Wiki to post or edit materials are also included on the Wiki itself. Students will be expected to periodically check the Wiki for information about the course.

Topical Coverage

- Op Amp and Comparator Design
 - Design strategies
 - Design space exploration *
 - Usage and performance requirements
 - Analysis, Noise/Dynamic Range, Simulation
 - Building Blocks
 - Current Mirrors
 - Common Source, Common Drain and Common Gate Amplifiers
 - Compensation
 - Amplifier Architectures

Topical Coverage (cont)

- Data converters : A/D and D/A
 - Nyquist-rate
 - Oversampled (if time permits)
- Voltage References
 - Bandgap References
 - V_T References
- Integrated Filter Design
 - Switched Capacitor
 - Continuous-Time
- Phase-locked Loops (if time permits)

Standard Way Analog Integrated Circuit Design is Taught/Learned

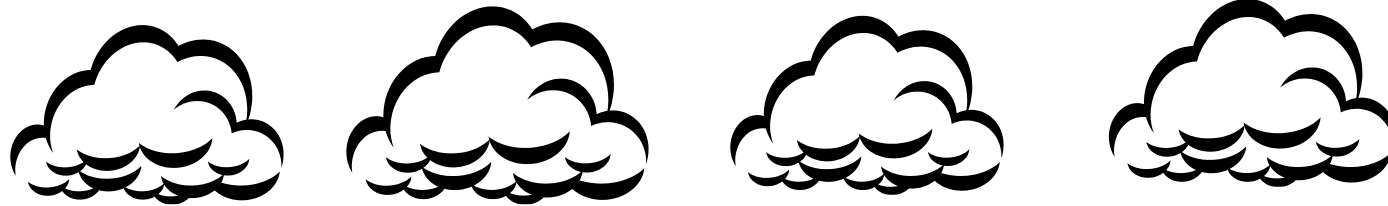

Appear

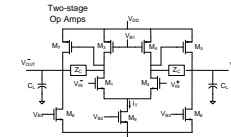
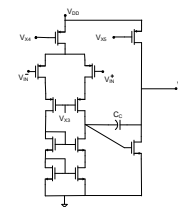
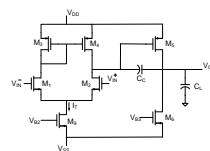
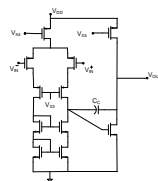
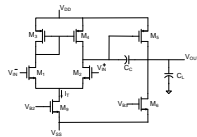

Analyze



Understand



Modify, Extend, and Create

Simulate and Verify

Will Attempt in the Course to Follow, as Much as Possible, the Following Approach

Understand



Synthesize

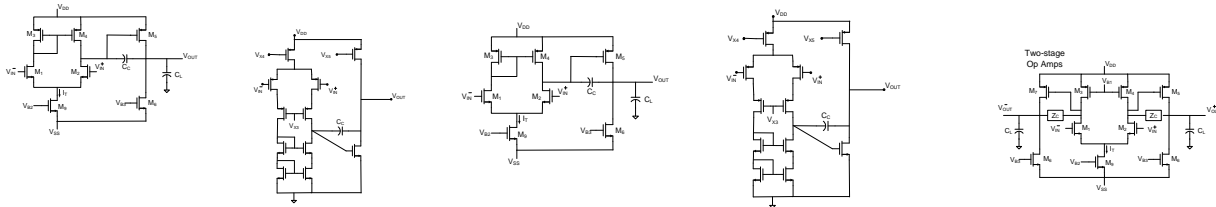

Analyze (if not available from the Understand step)

Modify, Extend, and Create



Simulate and Verify

Will Strongly Discourage This Approach

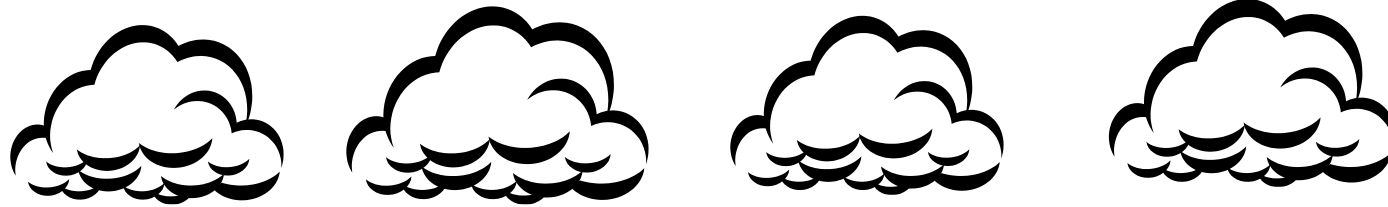

Appear

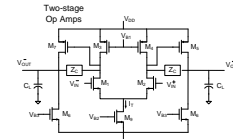
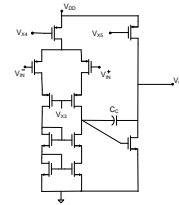
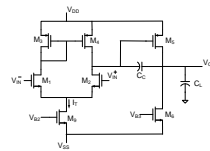
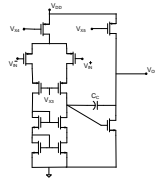
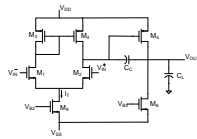

Modify, Extend, and Create



Simulate and Verify

Challenge to Students

Understand



Synthesize

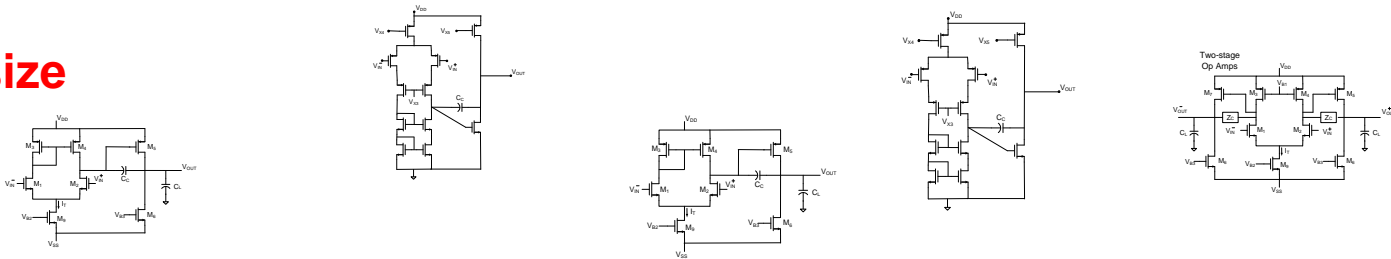

Ask **WHY?** for **ANY** concept that is not well understood !

Topical Coverage

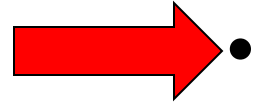

- Op Amp and Comparator Design
 - Design strategies
 - Design space exploration *
 - Usage and performance requirements
 - Building Blocks
 - Current Mirrors
 - Common Source, Common Drain and Common Gate Amplifiers
 - Simulation Strategies
 - Compensation
 - Amplifier Architectures

What is an operational amplifier ?



Fundamental Amplifier Design Issues

- ➔ Designer must be aware of what an amplifier really is
 - Designer must be aware of the real customer needs
 - Design requirements for application-specific amplifier dramatically different than those of catalog part
 - Many amplifiers are over-designed because real needs of customer not conveyed
 - Conventional wisdom will not necessarily provide best or even good or even viable solution

How does an amplifier differ from an operational amplifier?

- When operated linearly, an operational amplifier is a high gain amplifier that is intended to be used in a feedback application
 - Feedback is widely used to improve linearity and gain accuracy and the improvement is typically dramatic
- The more general amplifier is generally used open-loop
- Conventional wisdom : an open-loop amplifier is much simpler to design and use than an op amp, will have better high-frequency performance, will be less linear than feedback circuit with op amp and will be less accurate than feedback circuit with op amp

What is an Operational Amplifier?

Lets see what the experts say !



Consider one of the most popular textbooks on the subject used in the world today

A classic textbook that has helped educate two generations of engineers



First Edition 1982

Eighth Edition Nov 2019

\$229.99

In all editions, concept of the op amp has remained unchanged

2.1.2 Function and Characteristics of the Ideal Op Amp

We now consider the circuit function of the op amp. The op amp is designed to sense the difference between the voltage signals applied at its two input terminals (i.e., the quantity $v_2 - v_1$), multiply this by a number A , and cause the resulting voltage $A(v_2 - v_1)$ to appear at output terminal 3. Here it should be emphasized that when we talk about the voltage at a terminal we mean the voltage between that terminal and ground; thus v_1 means the voltage applied between terminal 1 and ground.

The ideal op amp is not supposed to draw any input current; that is, the signal current into terminal 1 and the signal current into terminal 2 are both zero. In other words, the input impedance of an ideal op amp is supposed to be infinite.

How about the output terminal 3? This terminal is supposed to act as the output terminal of an ideal voltage source. That is, the voltage between terminal 3 and ground will always be equal to $A(v_2 - v_1)$, independent of the current that may be drawn from terminal 3 into a load impedance. In other words, the output impedance of an ideal op amp is supposed to be zero.



From earlier edition

Page.jpg
 JPEG Image
 1.46 MB
 Dimension: 2144 x 2832 pixels

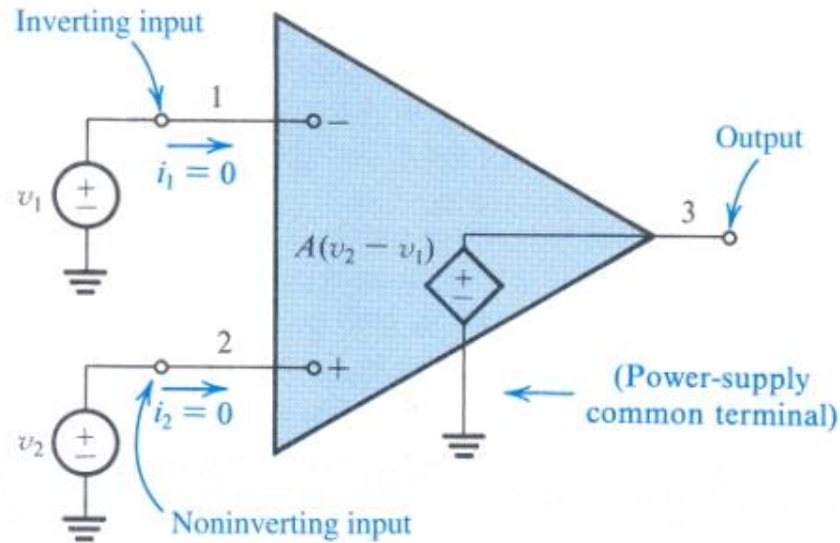

FIGURE 2.3 Equivalent circuit of the ideal op amp.

TABLE 2.1 Characteristics of the Ideal Op Amp

1. Infinite input impedance
2. Zero output impedance
3. Zero common-mode gain or, equivalently, infinite common-mode rejection
4. Infinite open-loop gain A
5. Infinite bandwidth

Operational Amplifiers

From eighth edition

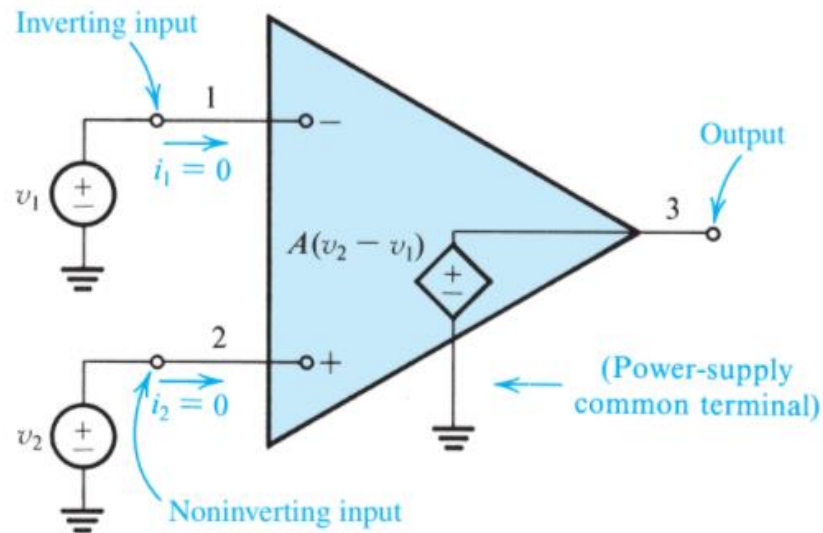
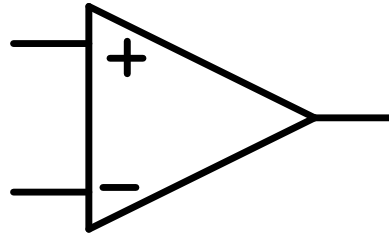

Table 2.1 Characteristics of the Ideal Op Amp

1. Infinite input impedance
2. Zero output impedance
3. Zero common-mode gain or, equivalently, infinite common-mode rejection
4. Infinite open-loop gain A
5. Infinite bandwidth

What is an Operational Amplifier?



Textbook Definition:

- Voltage Amplifier with Very Large Gain
 - Very High Input Impedance
 - Very Low Output Impedance
 - Silent on noise
 - Differential Input and Single-Ended Output
- This represents the Conventional Wisdom !

Does this correctly reflect what an operational amplifier really is?

Operational Amplifier Evolution in Time Perspective

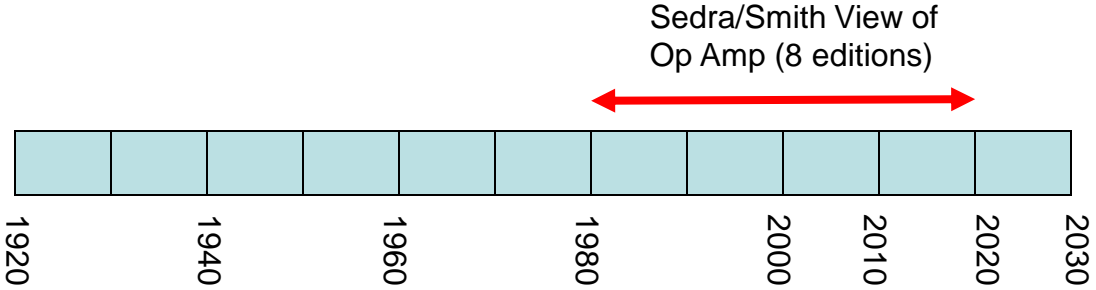

Consider some history leading up to the present concept of the operational amplifier

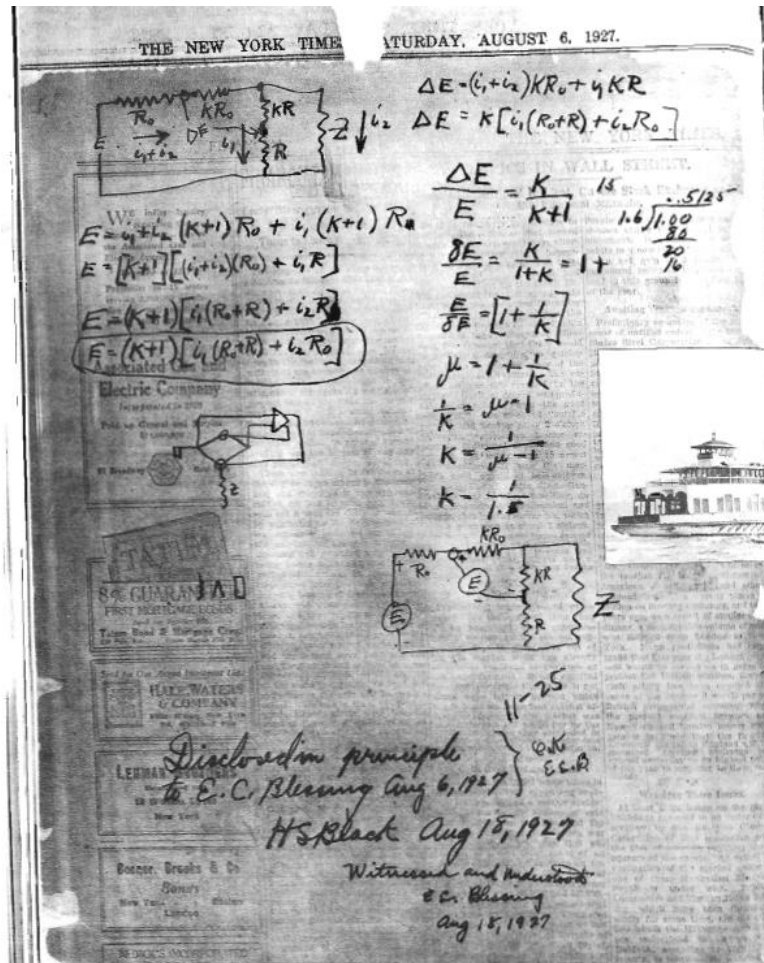

H.S. Black sketch of basic concept of feedback on Aug 6, 1927

Black did not use the term operational amplifier but rather focused on basic concepts of feedback involving the use of high-gain amplifiers

Why are Operational Amplifiers Used?

Harold Stephen Black (April 14, 1898 – December 11, 1983) was an American [electrical engineer](#), who revolutionized the field of applied electronics by inventing the [negative feedback](#) amplifier in 1927. To some, his invention is considered the most important breakthrough of the twentieth century in the field of [electronics](#), since it has a wide area of application. This is because all electronic devices (vacuum tubes, bipolar transistors and MOS transistors) invented by mankind are basically nonlinear devices. It is the invention of negative feedback which makes highly linear amplifiers possible. Negative feedback basically works by sacrificing gain for higher linearity (or in other words, smaller [distortion](#) or smaller [intermodulation](#)). By sacrificing gain, it also has an additional effect of increasing the bandwidth of the amplifier. However, a negative feedback amplifier can be unstable such that it may oscillate. Once the stability problem is solved, the negative feedback amplifier is extremely useful in the field of electronics. Black published a famous paper, *Stabilized feedback amplifiers*, in 1934.



Why are Operational Amplifiers Used?

H. Black, "Stabilized Feed-Back Amplifiers", Electrical Engineering, vol. 53, no. 1, pp. 114–120, Jan. 1934



“Due to advances in vacuum-tube development and amplifier technique, it now is possible to secure any desired amplification of the electrical waves used in the communication field. When many amplifiers are worked in tandem, however, it becomes difficult to keep the over-all circuit efficiency constant, variations in battery potentials and currents, small when considered individually, adding up to produce serious transmission changes for the over-all circuit. Furthermore, although it has remarkably linear properties, when the modern vacuum tube amplifier is used to handle a number of carrier telephone channels, extraneous frequencies are generated which cause interference between the channels. To keep this interference within proper bounds involves serious sacrifice of effective amplifier capacity or the use of a push-pull arrangement which, while giving some increase in capacity, adds to maintenance difficulty.

However, by building an amplifier whose gain is made deliberately, say 40 decibels higher than necessary (10000 fold excess on energy basis) and then feeding the output back to the input in such a way as to throw away the excess gain, **it has been found possible to effect extraordinary improvement in constancy of amplification and freedom from nonlinearity.**”

A classic textbook sequence that helped educate the previous generation of engineers

Vacuum Tube and
Semiconductor
Electronics

By Millman

First Edition 1958

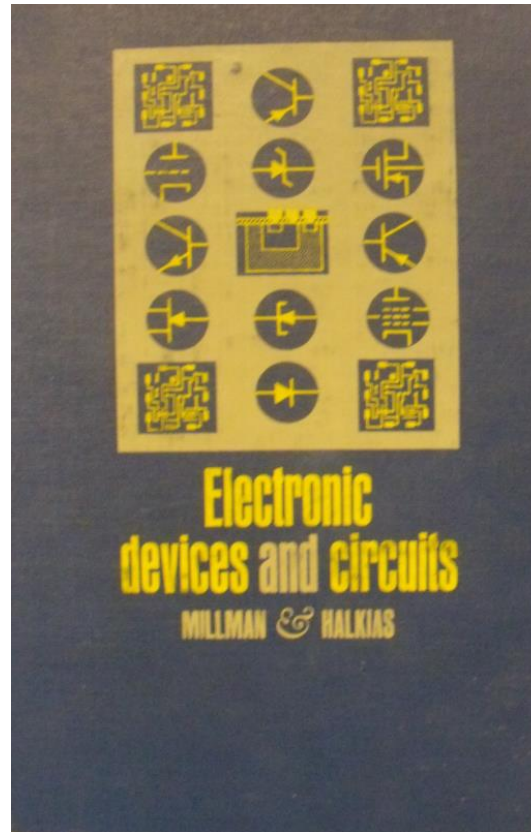

First Edition 1967

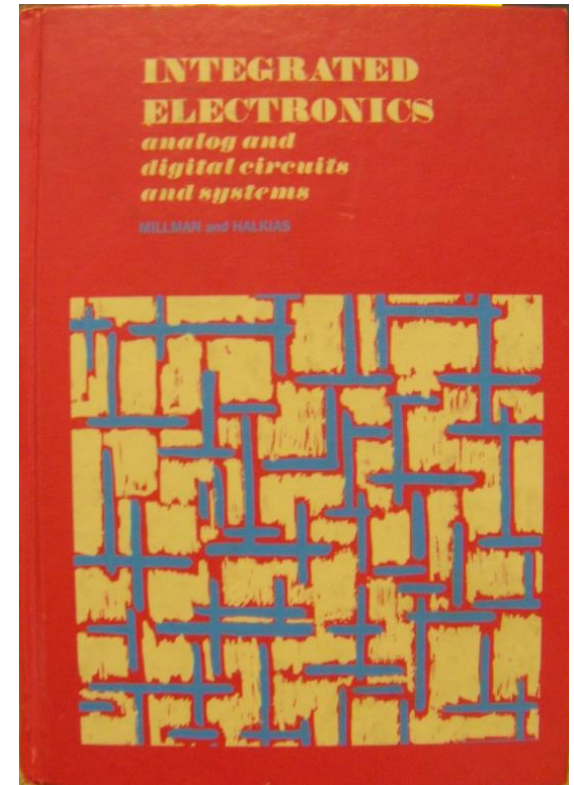

First Edition 1972

Millman view of an operational amplifier in 1967

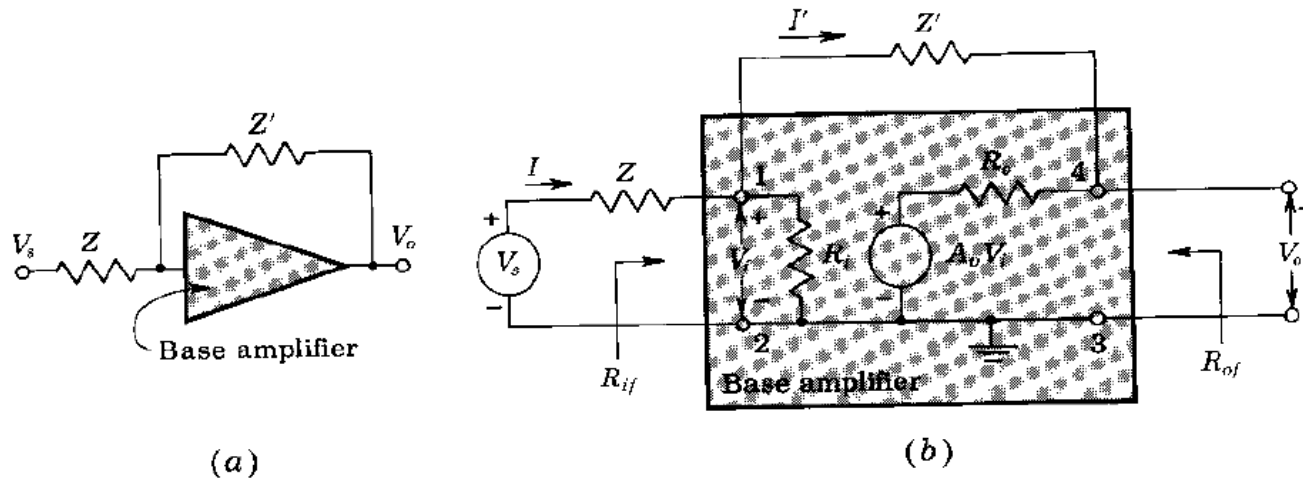
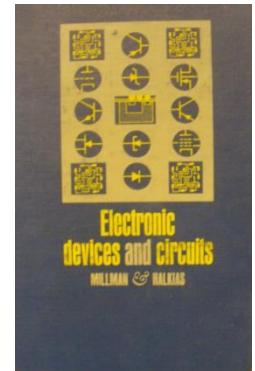

Fig. 17-26 (a) Schematic diagram and (b) equivalent circuit of an operational amplifier. The open-circuit voltage gain A_v is negative.

Operational Amplifier refers to the entire feedback circuit

Concept of a “Base Amplifier” as the high-gain amplifier block

Note Base Amplifier is modeled as a voltage amplifier with single-ended input and output

Millman view of an operational amplifier in 1972

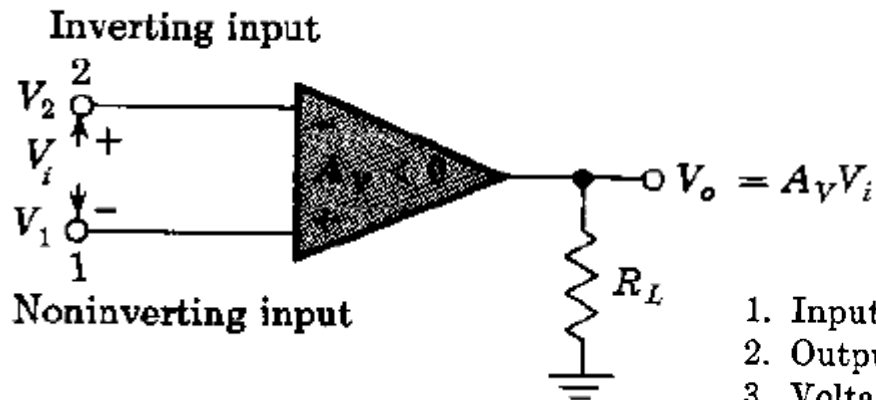

1. Input resistance $R_i = \infty$
2. Output resistance $R_o = 0$
3. Voltage gain $A_v = -\infty$
4. Bandwidth = ∞
5. $V_o = 0$ when $V_1 = V_2$ independent of the magnitude of V_1
6. Characteristics do not drift with temperature.

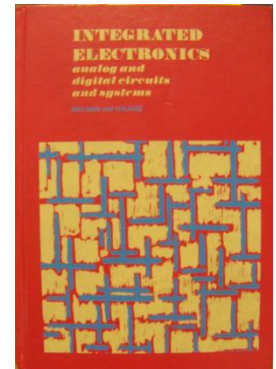

This book was published several years after the first integrated op amps were introduced by industry

This fundamentally agrees with that in use today by most authors

Major change in the concept from his own earlier works

Seminal source for “Operational Amplifier” notation:

444

PROCEEDINGS OF THE I.R.E.

May 1947

Analysis of Problems in Dynamics by Electronic Circuits*

JOHN R. RAGAZZINI[†], MEMBER, I.R.E., ROBERT H. RANDALL[‡], AND
FREDERICK A. RUSSELL[§], MEMBER, I.R.E.

The term “operational amplifier” is a generic term applied to amplifiers whose gain functions are such as to enable them to perform certain useful operations such as summation, integration, differentiation, or a combination of such operations.

Seminal source introduced a fundamentally different definition than what is used today

Consistent with the earlier use of the term by Millman

Seminal Publication of Feedback Concepts:

Stabilized Feed-Back Amplifiers

By
H. S. BLACK
MEMBER A.I.E.E.

Bell Telephone Laboratories, Inc.,
New York, N. Y.

Transactions of the American Institute of Electrical Engineers, Jan. 1934

Fig. 1. Amplifier system with feedback

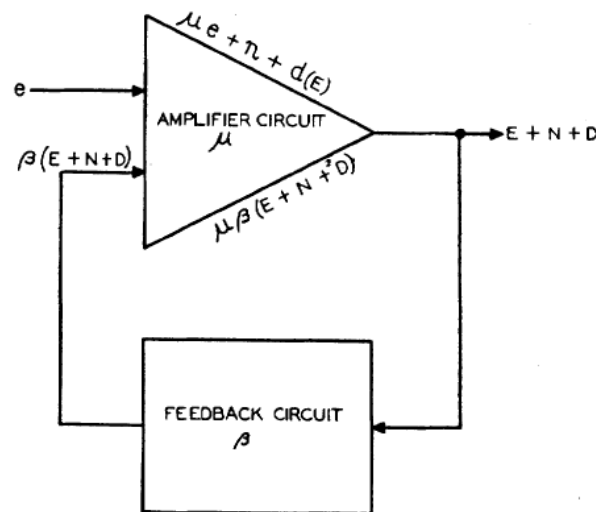

Uses a differential input high-gain voltage amplifier (voltage series feedback)

Subsequent examples of feedback by Black relaxed the differential input requirement

Operational Amplifier Evolution in Time Perspective

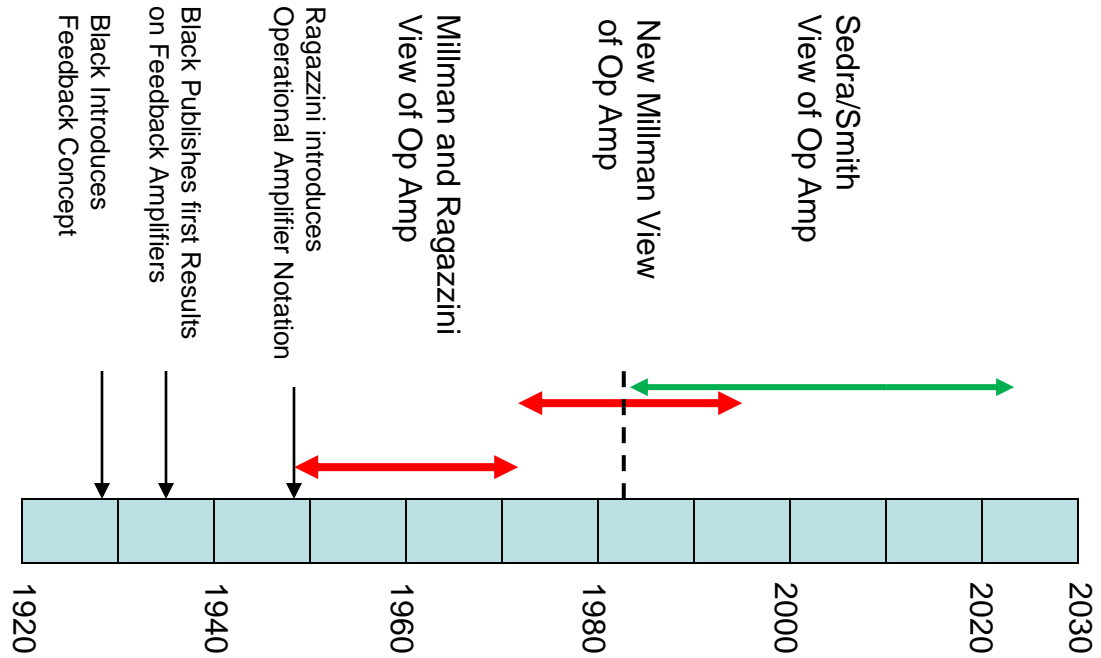

Do we have it right now?

Why are Operational Amplifiers Used?

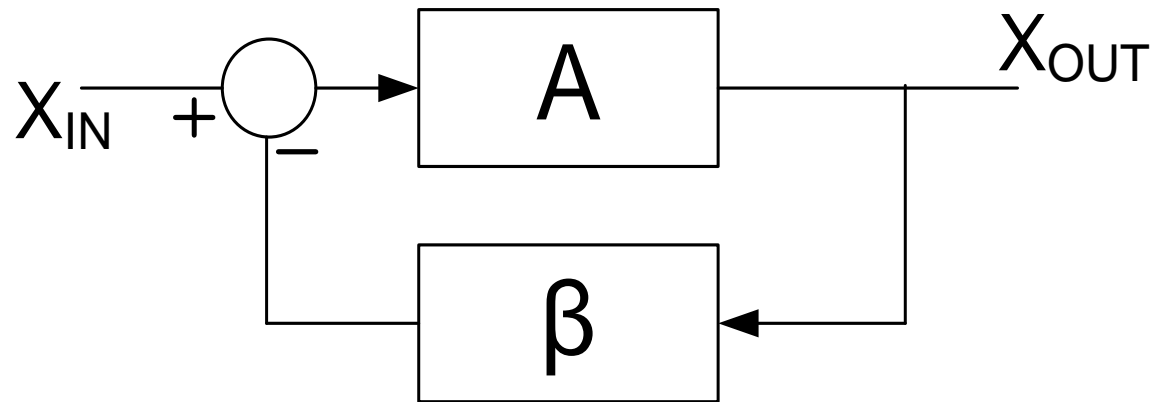

Input and Output Variables intentionally designated as “X” instead of “V”

$$\frac{X_{out}}{X_{in}} = A_F = \frac{A}{1 + A\beta} = \underset{\approx}{A \rightarrow \infty} \frac{1}{\beta}$$

Op Amp is Enabling Element Used to Build Feedback Networks !

What type of operational amplifier is needed?

Example: Standard Textbook Analysis of Finite Gain Voltage Amplifier

$$\left. \begin{aligned} V_1 &= \left(\frac{R_1}{R_1+R_2} \right) V_{OUT} + \left(\frac{R_2}{R_1+R_2} \right) V_{IN} \\ V_{OUT} &= -A_V V_1 \end{aligned} \right\}$$

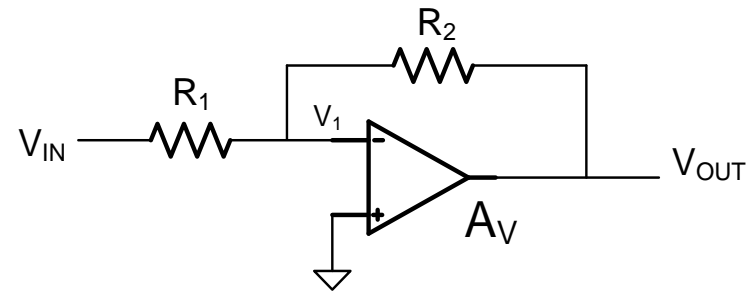

$$A_{VF} = \frac{V_{OUT}}{V_{IN}} = \frac{-\frac{R_2}{R_1}}{1 + \left(1 + \frac{R_2}{R_1} \right) \left(\frac{1}{A_V} \right)} \stackrel{A_V \rightarrow \infty}{\cong} -\frac{R_2}{R_1}$$

Implicit Assumption: Op Amp is a high gain voltage amplifier with infinite input impedance and zero output impedance

Does this imply that operational amplifiers (at least for this application) should be good voltage amplifiers?

One of the Most Basic Op Amp Applications

Model of Op Amp/Amplifier including A_V , R_{IN} , R_O and R_L

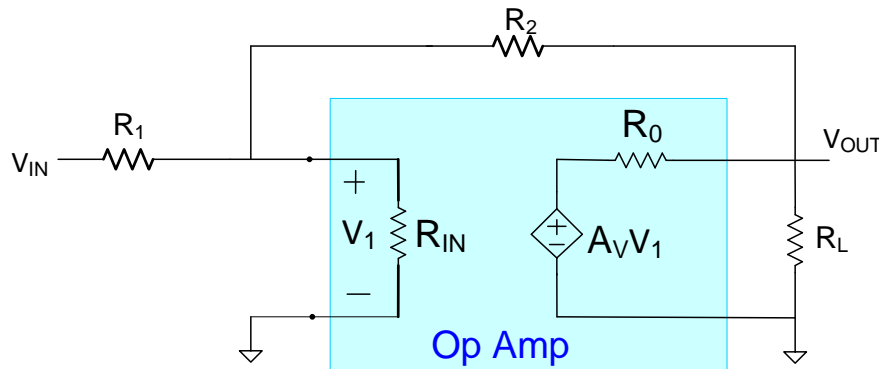

From KCL at two nodes:

$$\left. \begin{aligned} V_1(G_1 + G_2 + G_{IN}) &= V_{IN}G_1 + V_{OUT}G_2 \\ V_{OUT}(G_2 + G_O + G_L) &= V_1A_VG_O + G_2V_1 \end{aligned} \right\}$$

$$\frac{V_{OUT}}{V_{IN}} = \frac{G_1(A_VG_O + G_2)}{(G_2 + G_O + G_L)(G_1 + G_2 + G_{IN}) - A_VG_OG_2}$$

If A_V is large

$$\frac{V_{OUT}}{V_{IN}} = \frac{G_1(A_VG_O)}{-A_VG_OG_2} = \frac{G_1}{-G_2} = -\frac{R_2}{R_1}$$

This result is not dependent upon R_{IN} , R_O or R_L

So why was it necessary to assume R_{IN} is large and R_O is small and why was R_L ignored?

The Four Basic Types of Amplifiers:

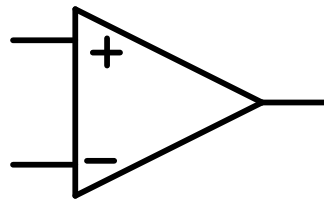

Voltage

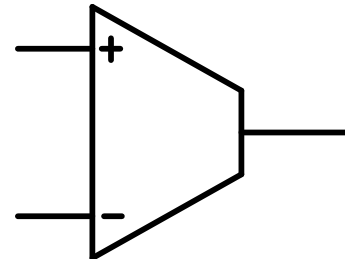

Transconductance

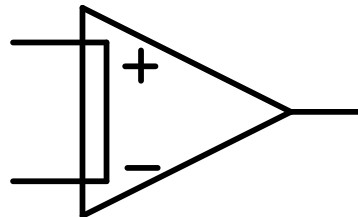

Transresistance

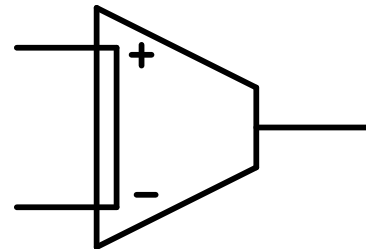

Current

The Four Basic Types of Amplifiers:

Two-Port Models of Ideal Amplifiers

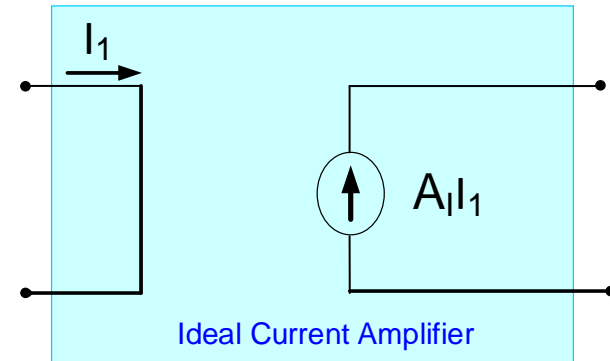
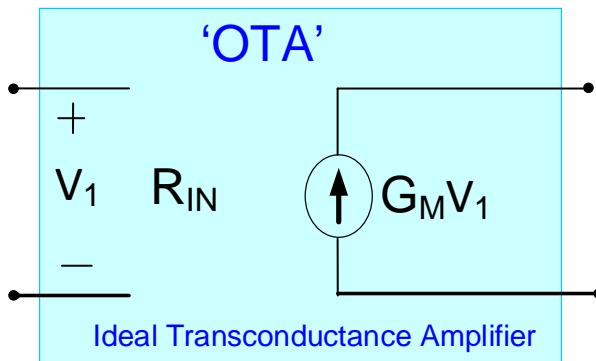
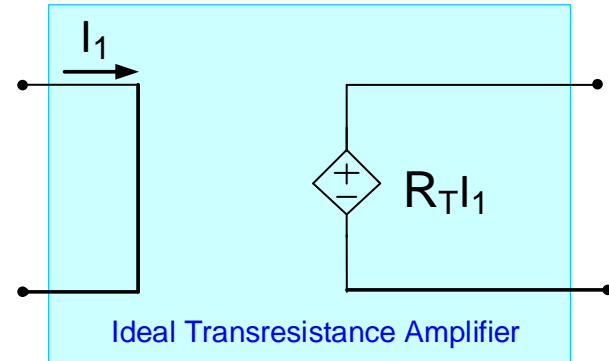
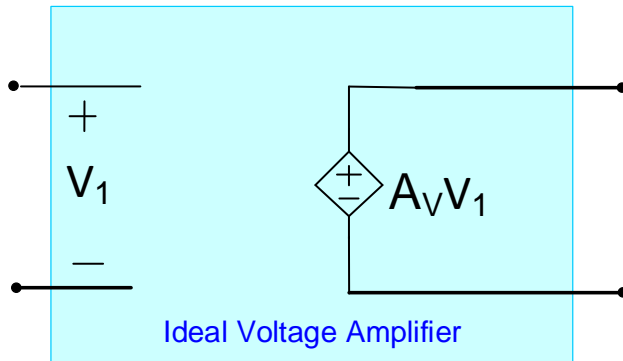

What type of operational amplifier is needed?

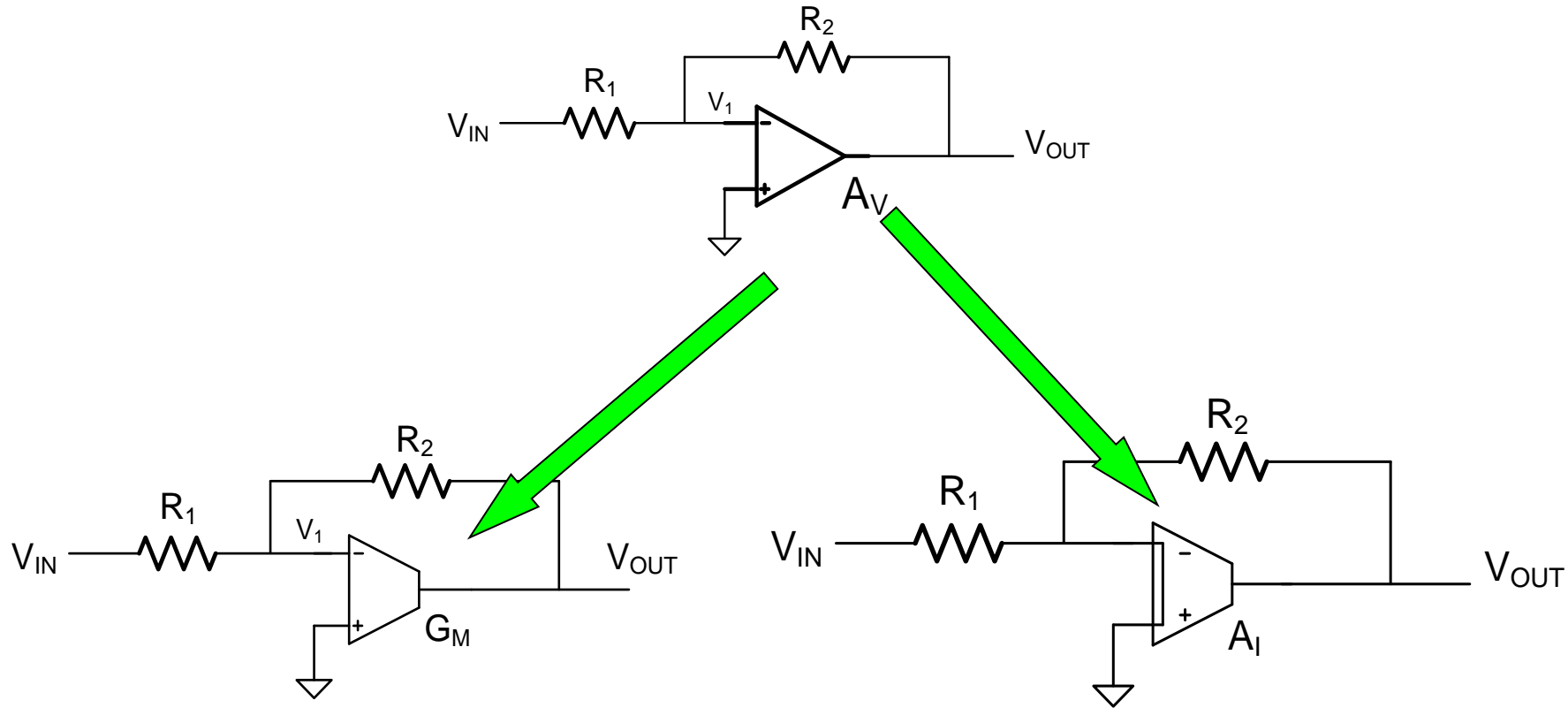

How would this feedback voltage amplifier perform if the voltage op amp were replaced with a transconductance op amp or a current op amp?

What type of operational amplifier is needed?

Consider using ideal OTA for “Op Amp”

$$\left. \begin{aligned} I_{OUT} &= -G_M V_1 \\ V_1 &= \left(\frac{R_1}{R_1 + R_2} \right) V_{OUT} + \left(\frac{R_2}{R_1 + R_2} \right) V_{IN} \\ V_{OUT} &= V_1 + I_{OUT} R_2 \end{aligned} \right\}$$

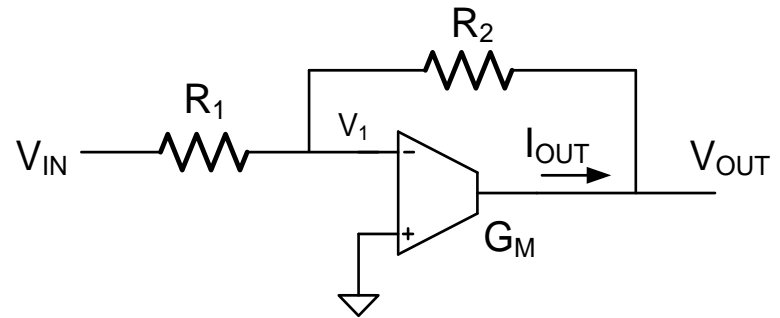

$$A_{VF} = \frac{V_{OUT}}{V_{IN}} = \frac{-\frac{R_2}{R_1}}{1 + \left(1 + \frac{R_2}{R_1} \right) \left(\frac{1}{G_M R_2 - 1} \right)} \stackrel{G_M \rightarrow \infty}{\approx} -\frac{R_2}{R_1}$$

Voltage gain with feedback is identical to that obtained with a “voltage” Op Amp provided G_M large !

What type of operational amplifier is needed?

Consider using ideal Current Amplifier for “Op Amp”

$$\left. \begin{aligned} V_{\text{OUT}} &= I_{\text{OUT}} R_2 \\ I_1 &= \frac{V_{\text{IN}}}{R_1} + \frac{V_{\text{OUT}}}{R_2} \\ I_{\text{OUT}} &= -A_I I_1 \end{aligned} \right\}$$

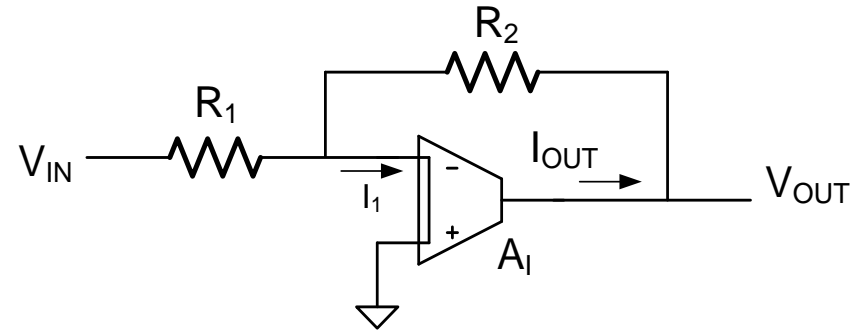

$$A_{\text{VF}} = \frac{V_{\text{OUT}}}{V_{\text{IN}}} = \frac{-\frac{R_2}{R_1}}{1 + \frac{1}{A_I}} \stackrel{A_I \rightarrow \infty}{\approx} \rightarrow -\frac{R_2}{R_1}$$

Voltage gain with feedback is identical to that obtained with a “voltage” Op Amp provided A_I large !

What type of operational amplifier is needed?

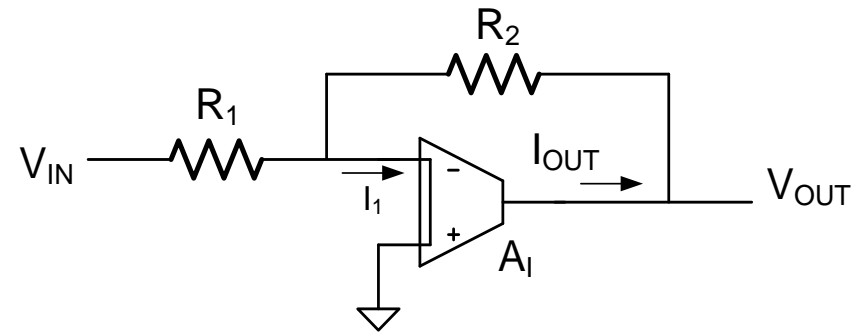
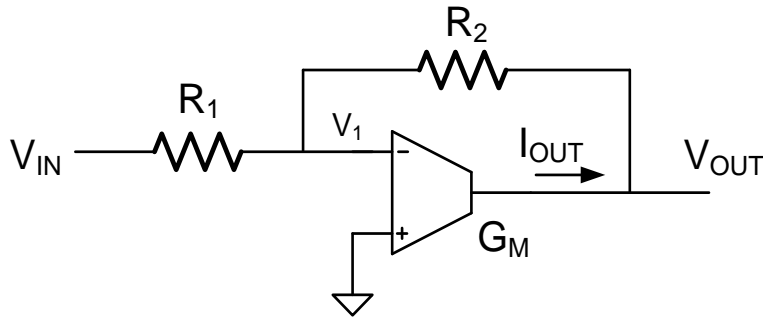

How would the voltage gain have changed with the transconductance amplifier or the current amplifier if R_{IN}, R_{OUT}, and R_L were included?

Voltage gain with feedback is identical to that obtained with a “voltage” Op Amp provided G_M or A_I are large !

What type of operational amplifier is needed?

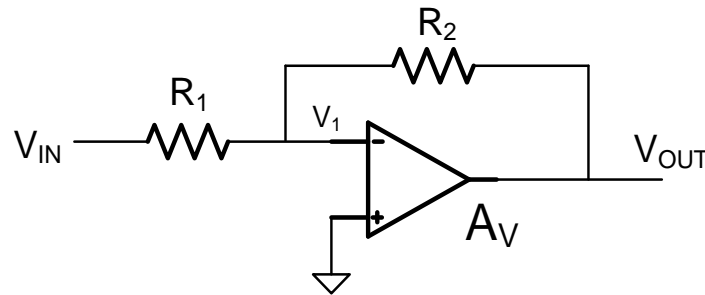

All four types of amplifiers will give the same closed loop gain provided the corresponding open loop gain is sufficiently large !

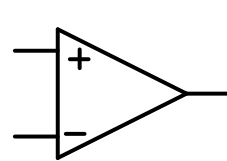

Voltage

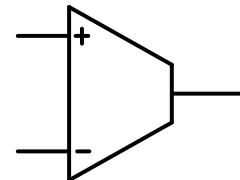

Transconductance

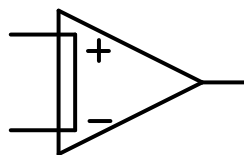

Transresistance

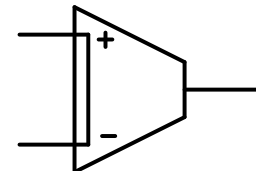

Current

A large gain is needed for an operational amplifier and if the gain is sufficiently large, the type of amplifier, the port input and output impedances, and the load are not of concern

Four Feedback Circuits with Same β Network

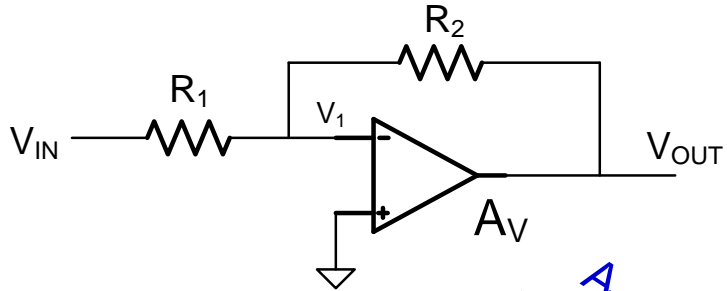

A_V Large

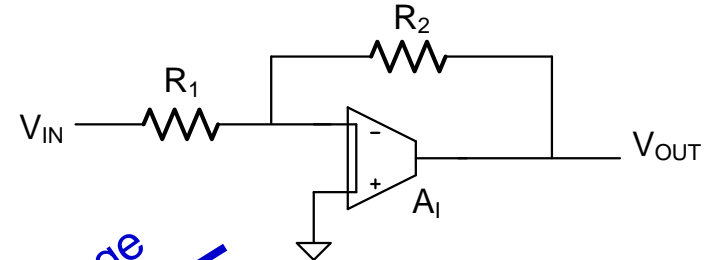

A_I Large

$$\frac{v_{OUT}}{v_{IN}} = -\frac{R_2}{R_1}$$

G_M Large

R_T Large

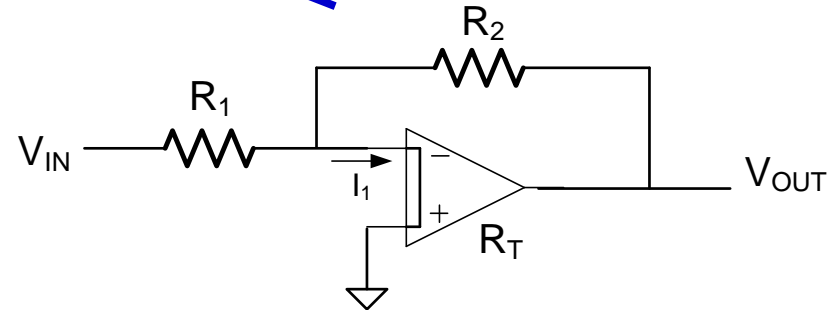
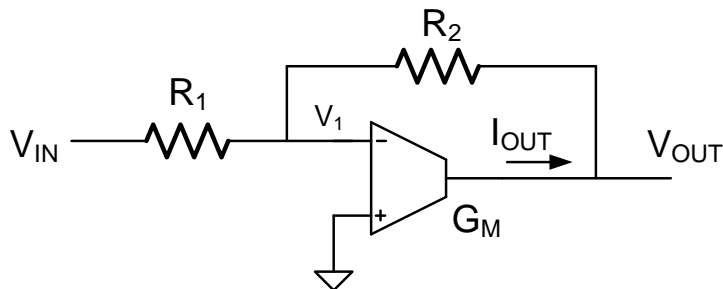

All have same closed-loop gain and all are independent of R_{IN} , R_{OUT} and R_L if gain is large 72

Amplifier Types

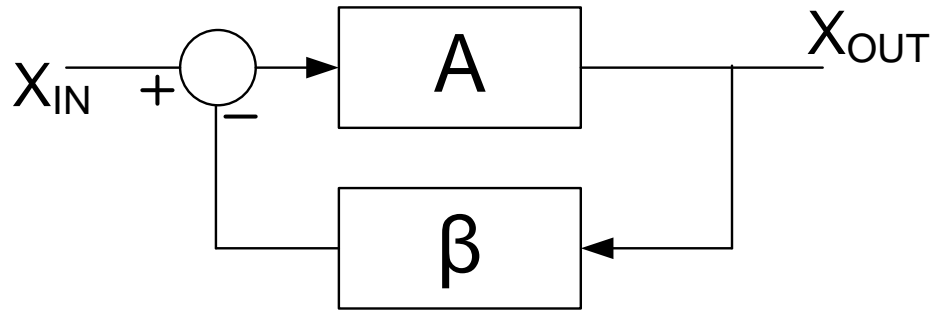

$$A_F = \frac{X_{OUT}}{X_{IN}} = \frac{A}{1+A\beta} \stackrel{A \rightarrow \infty}{\approx} \frac{1}{\beta}$$

Port Variables		Type of Amplifier		Amplifier Terminology
X _{in}	X _{out}	A	β	Op Amp Transconductance Transresistance Current
V	V	Voltage	Voltage	
V	I	Transconductance	Transresistance	
I	V	Transresistance	Transconductance	
I	I	Current	Current	

What type of operational amplifier is needed?

What type of operational amplifier is needed?

Port Variables		Amplifier Terminology	Ideal Port Impedances	
X_{in}	X_{out}		Input	Output
V	V	Op Amp	∞	0
V	I	T ransconductance	∞	∞
I	V	T ransresistance	0	0
I	I	Current	0	∞

Different types of op amps can be used in feedback amplifier but summing network performs different functions depending upon type of op amp used !

Dramatic Differences in Ideal Port Impedances!

What is an Operational Amplifier?

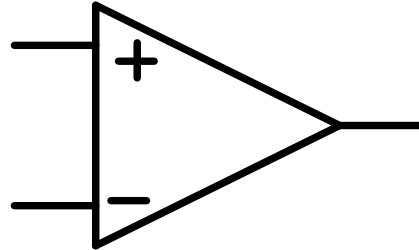

Textbook Definition:

- Voltage Amplifier with Very Large Gain
 - Very High Input Impedance
 - Very Low Output Impedance
 - Silent on noise
- Differential Input and Single-Ended Output

If the high input impedance and low output impedance are not needed and amplifier need not be a voltage amplifier, how about the other properties?

What is an Operational Amplifier?

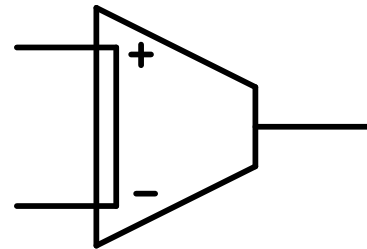
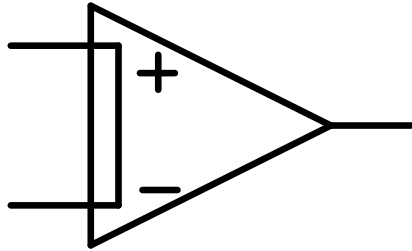
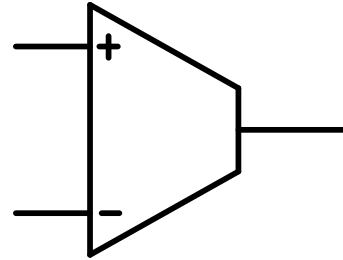
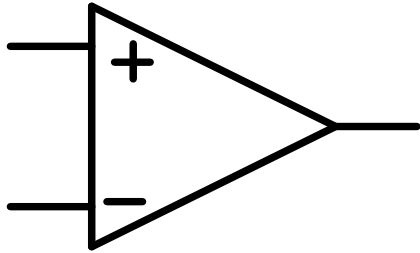

- Amplifier with Very Large Gain
- Differential Input and Single-Ended Output ?

Are differential input and single-ended outputs needed?

Consider Basic Amplifiers

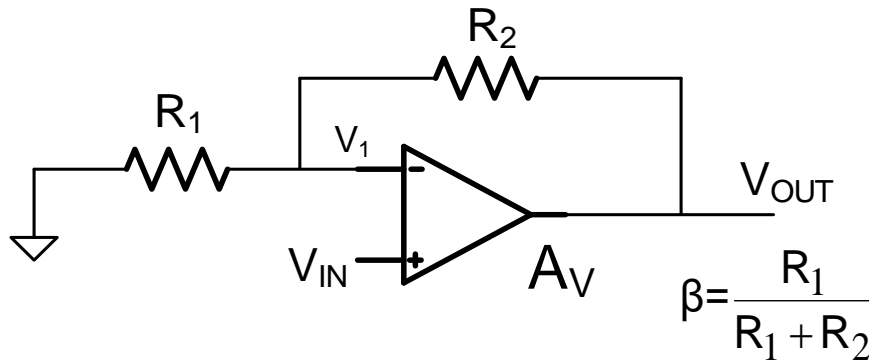

$$A_{VF} = \frac{V_{OUT}}{V_{IN}} = \frac{A_V}{1 + A_V \beta} \stackrel{A_V \rightarrow \infty}{\approx} \frac{1}{\beta}$$

Noninverting Amplifier

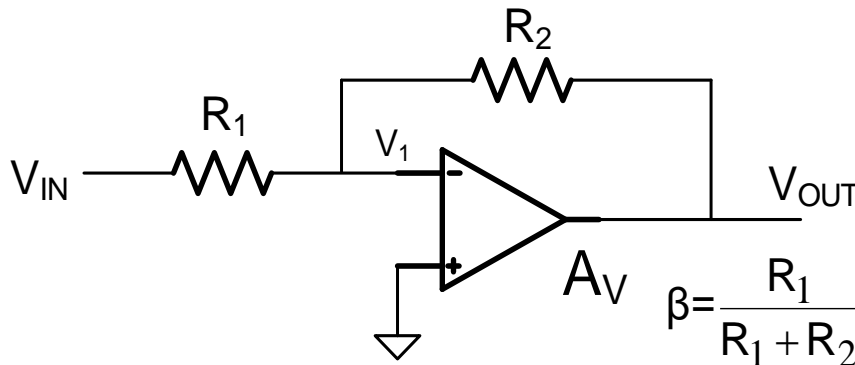

$$A_{VF} = \frac{V_{OUT}}{V_{IN}} = \frac{-A_V \beta_1}{1 + A_V \beta} \stackrel{A_V \rightarrow \infty}{\approx} \frac{-\beta_1}{\beta}$$

Inverting Amplifier

$$\beta_1 = \frac{R_2}{R_1 + R_2}$$

Only single-ended input is needed for Inverting Feedback Amplifier !

Many applications only need single-ended inputs !

A_{VF} is not equal to $1/\beta$!

Basic Inverting Amplifier Using Single-Ended Op Amp

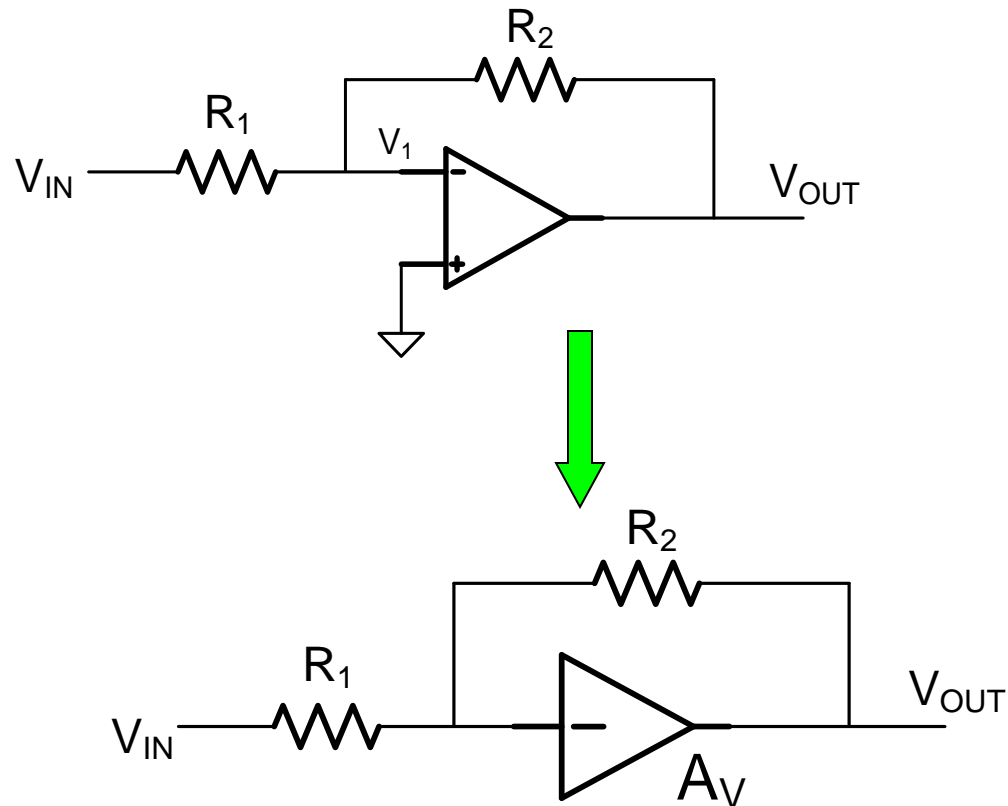

Inverting Amplifier with Single-Ended Op Amp

Concept well known



AN-88

CMOS LINEAR APPLICATIONS

Gene Taatjes
JULY 1973

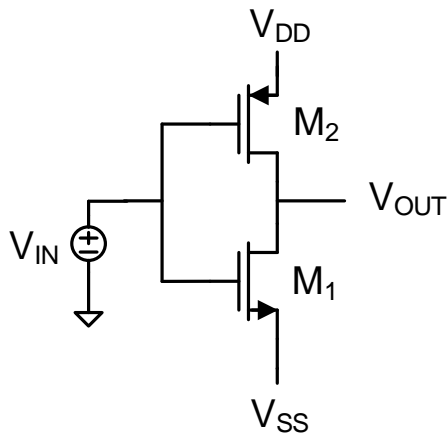

Current re-use amplifier

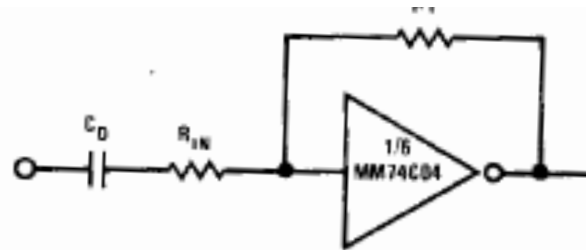
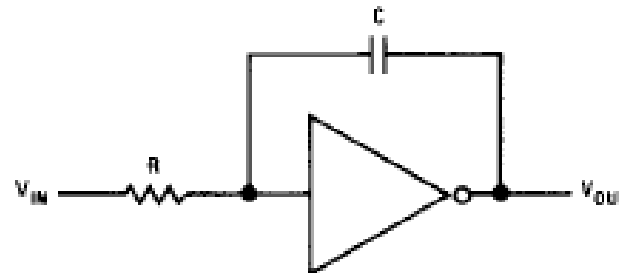

FIGURE 2. A 74CMOS Inverter Biased for Linear Mode Operation.



Integrator Using
Any Inverting CMOS Gate

Hex Inverters in 74C04 much less costly than 6 op amps at the time!

Fully Differential Amplifier

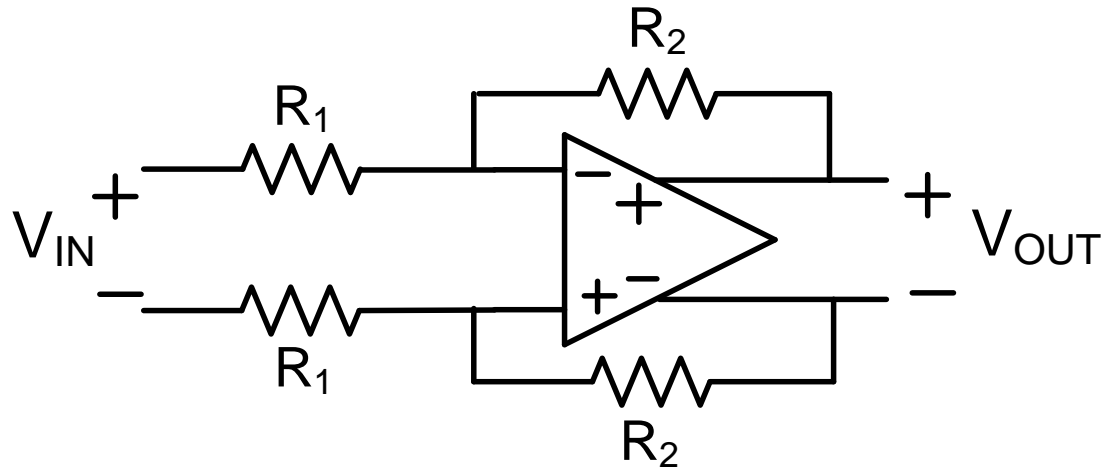

- Widely (almost exclusively) used in integrated amplifiers
- Seldom available in catalog parts

What is an Operational Amplifier?

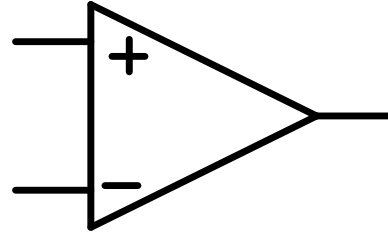

Textbook Definition:

- Voltage Amplifier
- Very Large Gain
- Differential Input and Single-Ended Outputs
- Very High Input Impedance
- Very Low Output Impedance
- Silent on noise

This represents the Conventional Wisdom !

Do we have it right now?

~~Voltage Amplifier?~~

~~Low Output Impedance?~~

~~Single-Ended Output?~~

~~High Input Impedance?~~

~~Differential Input?~~

Large Gain !!!

**Application Dependent
Dynamic Range !!!**

Why are Operational Amplifiers Used?

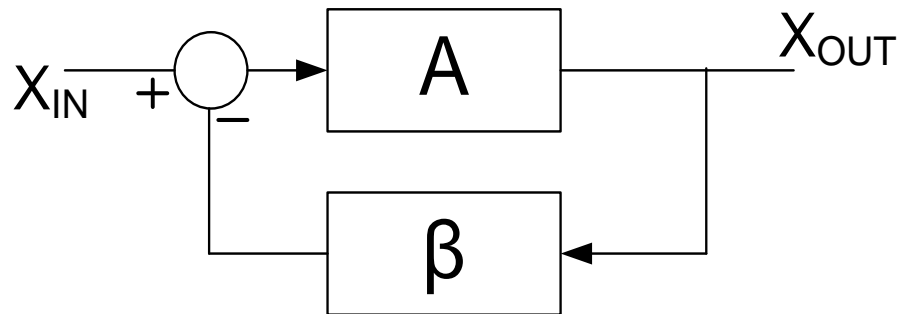

Input and Output Variables intentionally designated as “X” instead of “V”

$$\frac{X_{out}}{X_{in}} = A_F = \frac{A}{1 + A\beta} = \underset{A \rightarrow \infty}{\approx} \frac{1}{\beta}$$

May still be feedback but block diagram may differ from that above (e.g.)

$$A_{VF} = \frac{V_{OUT}}{V_{IN}} = \frac{-A\beta_1}{1 + A\beta} \underset{A \rightarrow \infty}{\approx} \frac{-\beta_1}{\beta}$$

Op Amp is Enabling Element Used to Build Feedback Networks !

What Characteristics are Really Needed for Op Amps?

$$A_F = \frac{A}{1 + A\beta} \approx \frac{1}{\beta} \qquad A_{VF} = \frac{-A\beta_1}{1 + A\beta} \approx \frac{-\beta_1}{\beta}$$

1. Very Large Gain

To make A_F (or A_{VF}) insensitive to variations in A

To make A_F (or A_{VF}) insensitive to nonlinearities of A

2. Port Configurations Consistent with Application

3. Application Dependent Dynamic Range

Port Configurations for Op Amps

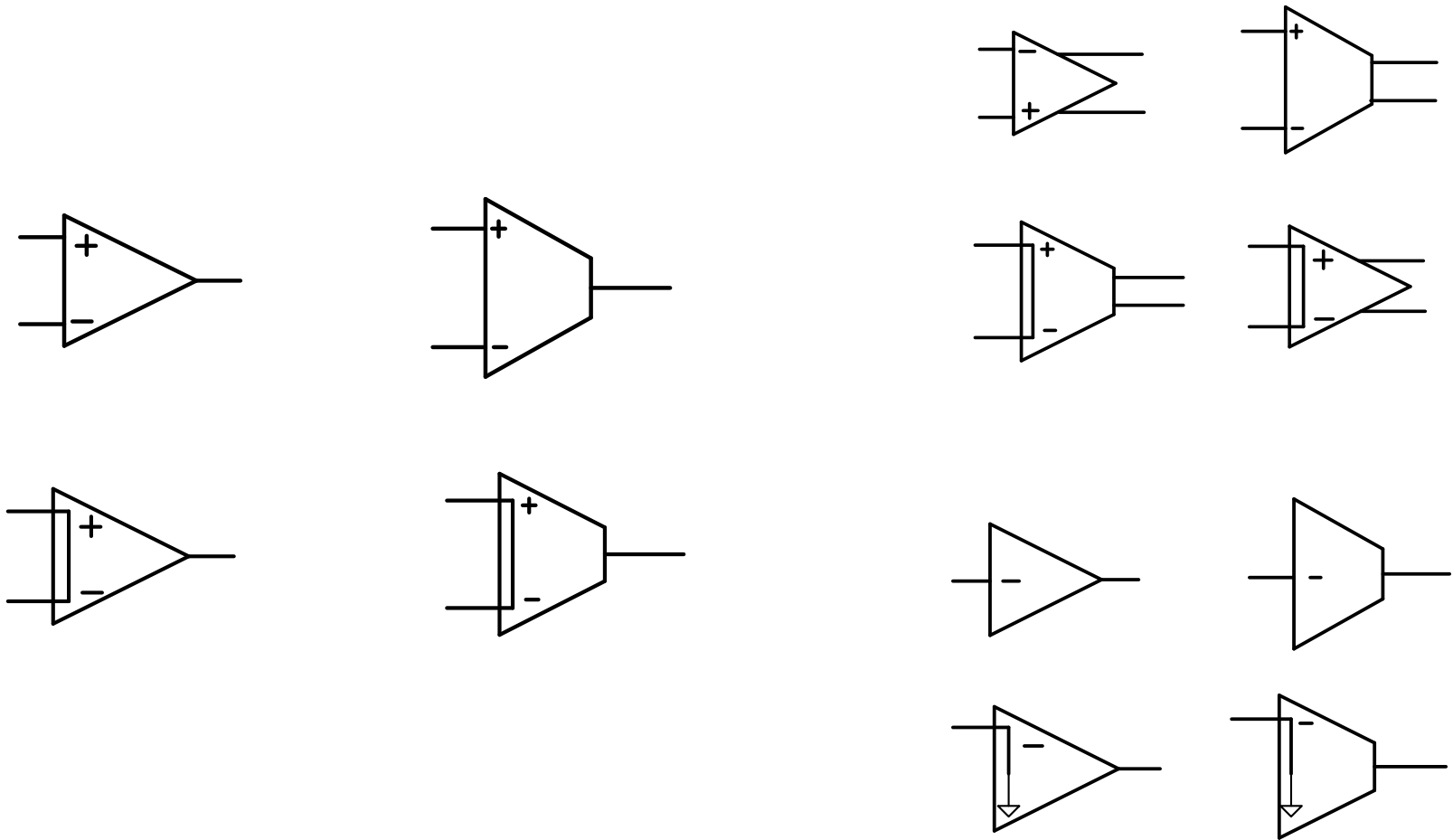

(Could also have single-ended input and differential output though less common)

What Characteristics do Many Customers and Designers Assume are Needed for Op Amps?

1. **Very Large Voltage Gain**

and ...

2. Low Output Impedance
3. High Input Impedance
4. Large Output Swing
3. Large Input Range
4. Low Noise
5. Good High-frequency Performance
6. Fast Settling
7. Adequate Phase Margin
8. Good CMRR
9. Good PSRR
10. Low Power Dissipation
11. Reasonable Linearity
12. ▪ ▪ ▪

What Characteristics are **Really** Needed for Op Amps?

- For Catalog Components
 - Those that are needed for the data sheet
- For Integrated Op Amp
 - Only those that are needed for the specific application
 - Often only one or two characteristics are of concern in a specific application

Avoid over-design to meet performance specifications that are not needed!

What is an Operational Amplifier?

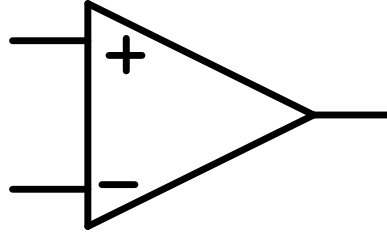

Textbook Definition:

- Voltage Amplifier
- Very Large Gain
- Differential Input and Single-Ended Outputs
- Very High Input Impedance
- Very Low Output Impedance
- Silent on noise

This represents the Conventional Wisdom !

Do we have it right now?

Operational Amplifier Evolution in Time Perspective

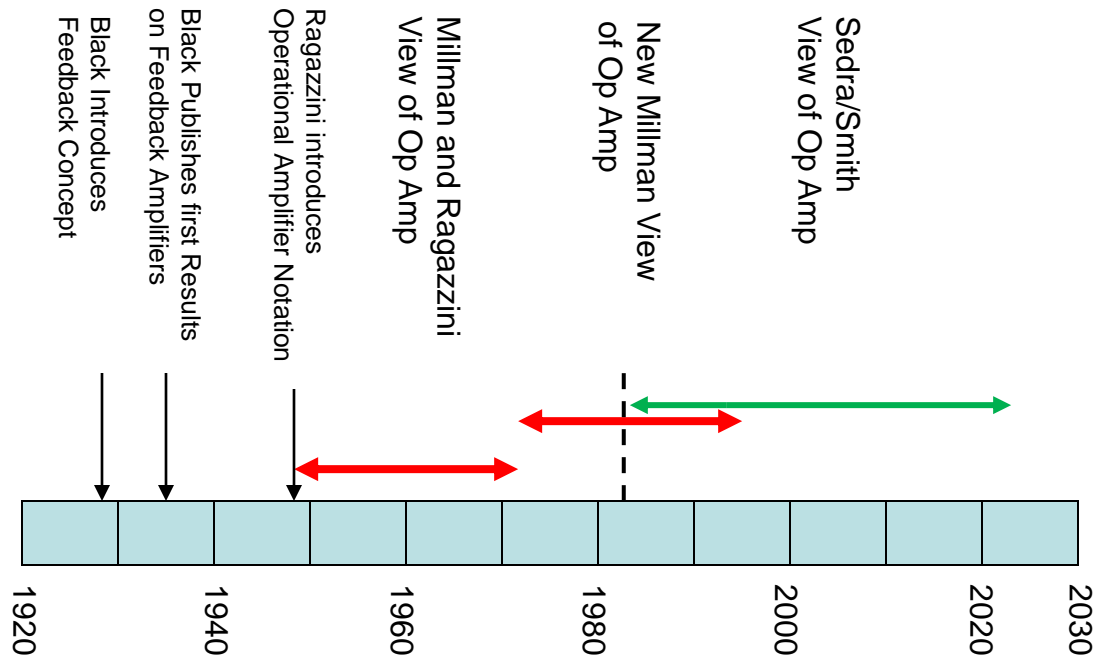

Do we have it right now?

You be the judge !

Challenge to Students

Understand



Ask **WHY?** for **ANY** concept that is not well understood !

par·a·dox

/ˈperəˌdäks/

a statement or proposition that, despite sound (or apparently sound) reasoning from acceptable premises, leads to a conclusion that seems senseless, logically unacceptable, or self-contradictory.

- There are numerous concepts in the engineering community that appear to be paradoxes
- Paradoxes often arise when “Conventional Wisdom” is in conflict with science or truth
- Identifying and resolving a paradox often improves understanding and productivity
- Will attempt, in this course, to identify some paradoxes that exist in the circuits community
- Please bring forward any paradoxes that you may see in the field !!



Stay Safe and Stay Healthy !

End of Lecture 1